

Service Manual

ED-5.1F PW

Stereo CD System

COMPACT
disc
DIGITAL AUDIO

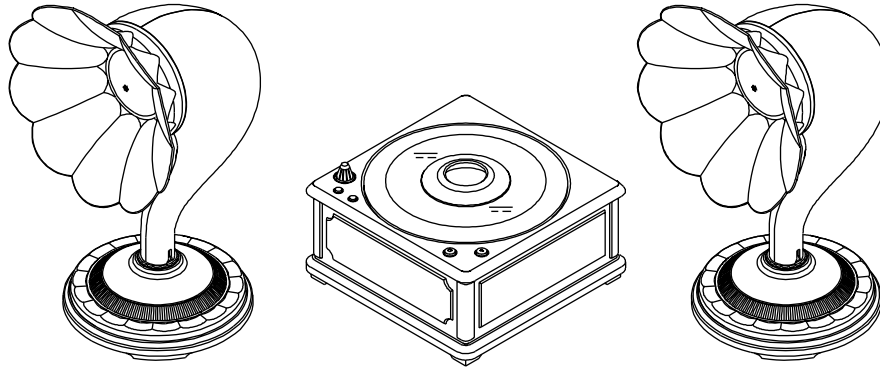

TABLE OF CONTENTS

SECTION	PAGE
1. TECHNICAL SPECIFICATIONS	1
2. SERVICE MODE	2
3. BLOCK DIAGRAM	3
4. SCHEMATIC DIAGRAM	5
5. PARTS LOCATION	13
6. IC DATA	18
7. EXPLODED VIEW AND PARTS LIST	25
8. ELECTRICAL PARTS LIST	28

Please use this service manual with referring to the user guide (D.F.U.) without fail.

修理の際は、必ず取扱説明書を準備し操作方法を確認の上作業を行ってください。

marantz®

R100

古紙配合率100%再生紙を使用しています
Printed on 100% Recycled Paper

Printed in Japan

ED-5.1

05AW855010 MIT
First Issue 2001.10

ED-5.1

MARANTZ DESIGN AND SERVICE

Using superior design and selected high grade components, **MARANTZ** company has created the ultimate in stereo sound. Only original **MARANTZ** parts can insure that your **MARANTZ** product will continue to perform to the specifications for which it is famous.

Parts for your **MARANTZ** equipment are generally available to our National Marantz Subsidiary or Agent.

ORDERING PARTS :

Parts can be ordered either by mail or by Fax.. In both cases, the correct part number has to be specified.

The following information must be supplied to eliminate delays in processing your order :

1. Complete address
2. Complete part numbers and quantities required
3. Description of parts
4. Model number for which part is required
5. Way of shipment
6. Signature : any order form or Fax. must be signed, otherwise such part order will be considered as null and void.

USA

MARANTZ AMERICA, INC.
1100 MAPLEWOOD DRIVE
ITASCA, IL. 60143
USA
PHONE : 630 - 741 - 0300
FAX : 630 - 741 - 0301

EUROPE / TRADING

MARANTZ EUROPE B.V.
P.O.BOX 80002, BUILDING SFF2
5600 JB EINDHOVEN
THE NETHERLANDS
PHONE : +31 - 40 - 2732241
FAX : +31 - 40 - 2735578

BRAZIL

PHILIPS DA AMAZONIA IND. ELET. ITDA
CENTRO DE INFORMACOES AO
CEP 04698-970
SAO PAULO, SP, BRAZIL
PHONE : 0800 - 123123(Discagem Direta Gratuita)
FAX : +55 11 534. 8988

PROFESSIONAL AMERICAS SUPERSCOPE TECHNOLOGIES, INC.

MARANTZ PROFESSIONAL PRODUCTS
2640 WHITE OAK CIRCLE, SUITE A
AURORA, ILLINOIS 60504 USA
PHONE : 630 - 820 - 4800
FAX : 630 - 820 - 8103

PROFESSIONAL AUSTRALIA TECHNICAL AUDIO GROUP PTY, LTD

558 DARLING STREET,
BALMAIN, NSW 2041,
AUSTRALIA
PHONE : 61 - 2 - 9810 - 5300
FAX : 61 - 2 - 9810 - 5355

CANADA

LENBROOK INDUSTRIES LIMITED
633 GRANITE COURT,
PICKERING, ONTARIO L1W 3K1
CANADA
PHONE : 905 - 831 - 6333
FAX : 905 - 831 - 6936

AUSTRALIA

QualIFI Pty Ltd,
24 LIONEL ROAD,
MT. WAVERLEY VIC 3149
AUSTRALIA
PHONE : +61 - (0)3 - 9543 - 1522
FAX : +61 - (0)3 - 9543 - 3677

THAILAND

MRZ STANDARD CO.,LTD
746 - 754 MAHACHAI ROAD.,
WANGBURAPAPIROM, PHRANAKORN,
BANGKOK, 10200 THAILAND
PHONE : +66 - 2 - 222 9181
FAX : +66 - 2 - 224 6795

SINGAPORE

WO KEE HONG DISTRIBUTION PTE LTD
130 JOO SENG ROAD
#03-02 OLIVINE BUILDING
SINGAPORE 368357
PHONE : +65 858 5535 / +65 381 8621
FAX : +65 858 6078

NEW ZEALAND

WILDASH AUDIO SYSTEMS NZ
14 MALVERN ROAD MT ALBERT
AUCKLAND NEW ZEALAND
PHONE : +64 - 9 - 8451958
FAX : +64 - 9 - 8463554

TAIWAN

PAI- YUING CO., LTD.
6 TH FL NO, 148 SUNG KIANG ROAD,
TAIPEI, 10429, TAIWAN R.O.C.
PHONE : +886 - 2 - 25221304
FAX : +886 - 2 - 25630415

MALAYSIA

WO KEE HONG ELECTRONICS SDN. BHD.
SUITE 8.1, LEVEL 8, MENARA GENESIS,
NO. 33, JALAN SULTAN ISMAIL,
50250 KUALA LUMPUR, MALAYSIA
PHONE : +60 3 - 2457677
FAX : +60 3 - 2458180

JAPAN *Technical*

MARANTZ JAPAN, INC.
35- 1, 7- CHOME, SAGAMIONO
SAGAMIHARA - SHI, KANAGAWA
JAPAN 228-8505
PHONE : +81 42 748 1013
FAX : +81 42 741 9190

日本マランツ株式会社

本社 〒228-8505
神奈川県相模原市相模大野7-35-1
営業本部 〒150-0022
東京都渋谷区恵比寿南1-11-9

KOREA

MK ENTERPRISES LTD.
ROOM 604/605, ELECTRO-OFFICETEL, 16-58,
3GA, HANGANG-RO, YONGSAN-KU, SEOUL
KOREA
PHONE : +822 - 3232 - 155
FAX : +822 - 3232 - 154

SHOCK, FIRE HAZARD SERVICE TEST :

CAUTION : After servicing this appliance and prior to returning to customer, measure the resistance between either primary AC cord connector pins (with unit NOT connected to AC mains and its Power switch ON), and the face or Front Panel of product and controls and chassis bottom.

Any resistance measurement less than 1 Megohms should cause unit to be repaired or corrected before AC power is applied, and verified before it is return to the user/customer.

Ref. UL Standard No. 1492.

In case of difficulties, do not hesitate to contact the Technical Department at above mentioned address.

1. TECHNICAL SPECIFICATIONS

CD Player Section

D/A conversion 1 bit DAC
Wow & flutter Precision of quartz

Horn Section

Speaker 5.0 cm (8 ohms) x 2
Dynamic type
Output jack 3.5 mm 4P mini-jack
Dimensions (W x H x D) 172 x 290 x 170 mm x 2
Weight 0.9kg x 2

Amplifire Section

Maximun output power 6 W (EIAJ)
S/N 80 dB
Power Consumption 19 W
Power Requirement AC 100 V, 50 / 60 Hz
Dimensions (W x H x D) 172 x 90 x 172 mm
Weight 1.9 kg

Accessories

3.5 mm mini-plug audio cable 1

Specifications subject to change without prior notice.

2. SERVICE MODE

定義： Player の機能のチェック。

表示： Service Mode による表示とする。

動作： Stop または No Disc 状態で NEXT、PREV、STOP の3つのキーを押しながら、PLAY キーを押す。

Service Mode に入った状態では b-0000(0000 は Build 番号によって変わる)の Software Build 番号を表示する。

b-1234

LCD Test の状態で、PLAY キーを押すと、CD Test に移行する。

CD Test には、Laser Test、Spindle Test、Pickup Test が含まれる。

Service Mode で STOP キーが入力されると、Reset される。

CD Test 状態で、PLAY キーが入力されると、LCD Test に戻る。その際、各 CD Test 状態は必ず Off となる。

Laser Test→Pickup Test→Spindle Test→Laser Test…の切り替えは NEXT キー入力によって行われる。

Laser Test 状態の場合、PREV キーによって On→Off→On…と切り替えられる。

52-LAS

Pickup Test 状態の場合、PREV キーによって Off→外側→内側→Off…と切り替えられる。

53-P IC

Spindle Test 状態の場合、PREV キーによって Clockwise→Counter Clockwise→Off→Clockwise…と切り替えられる。

54-S PL

その他：図参照

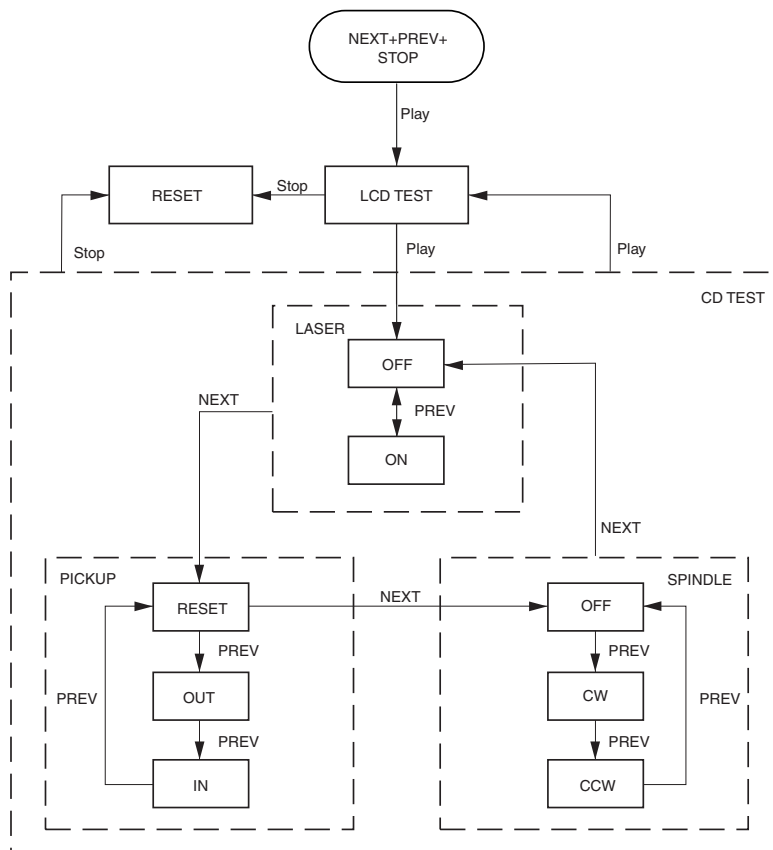

3. BLOCK DIAGRAM

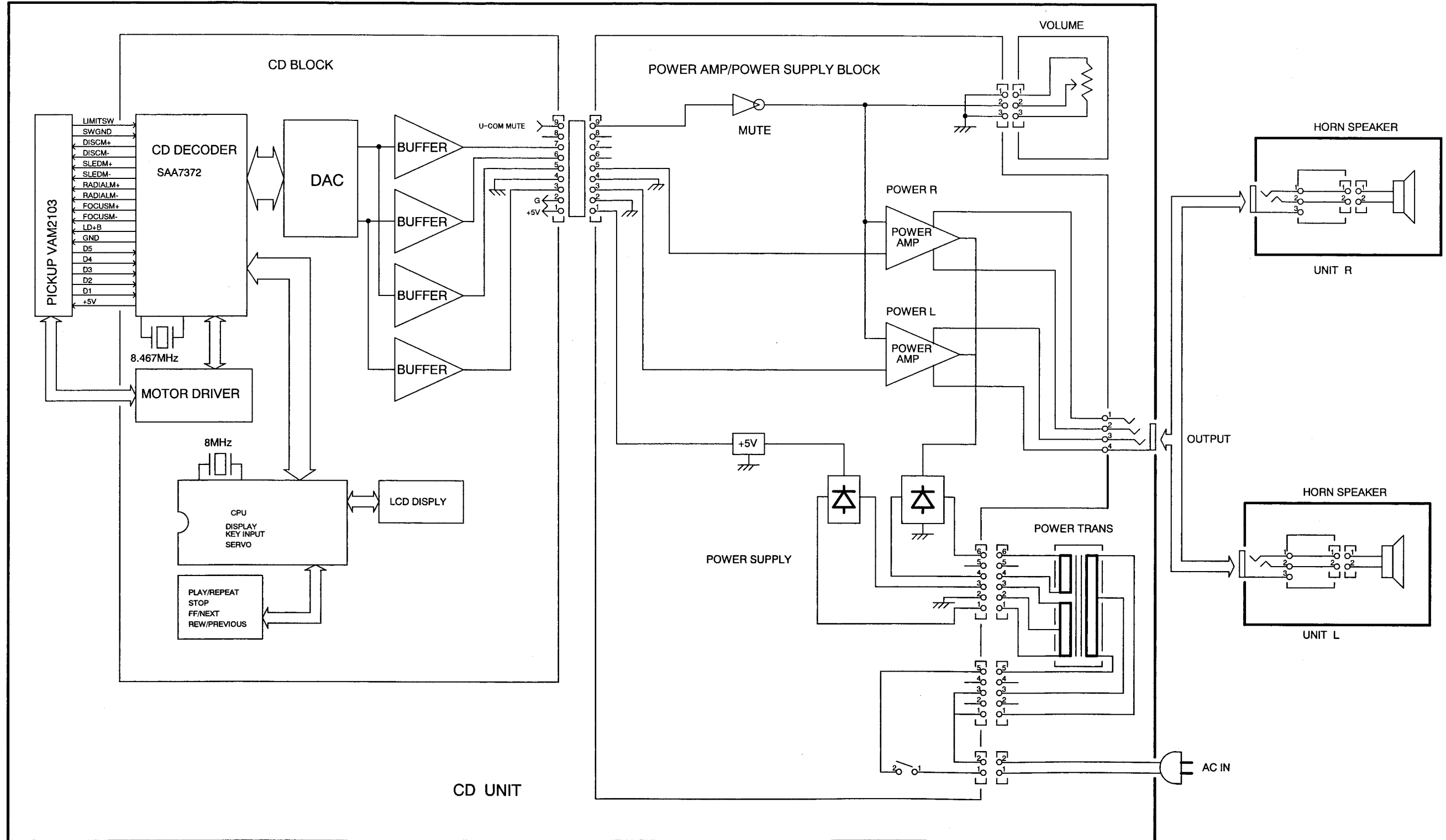

4. SCHEMATIC DIAGRAM

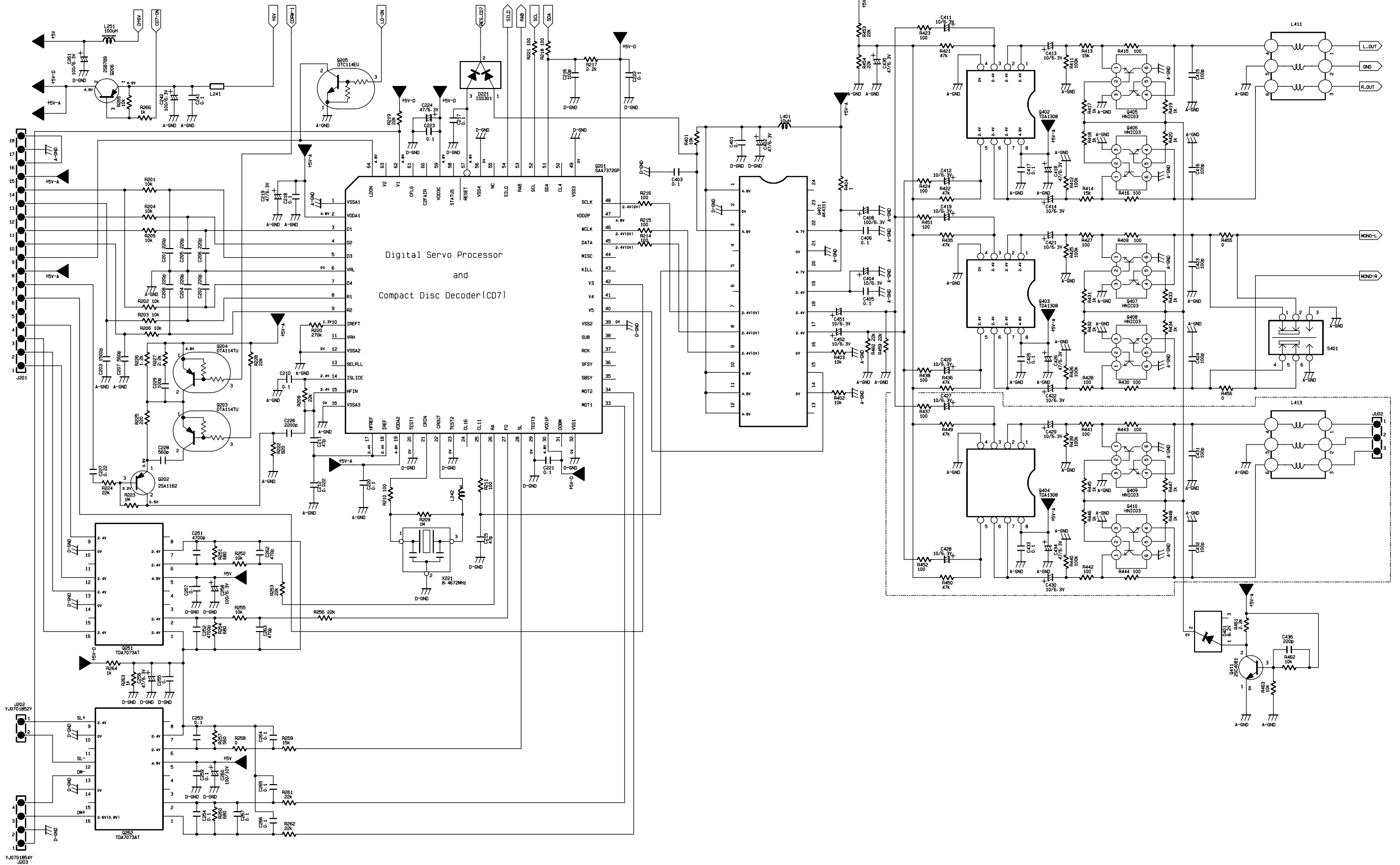

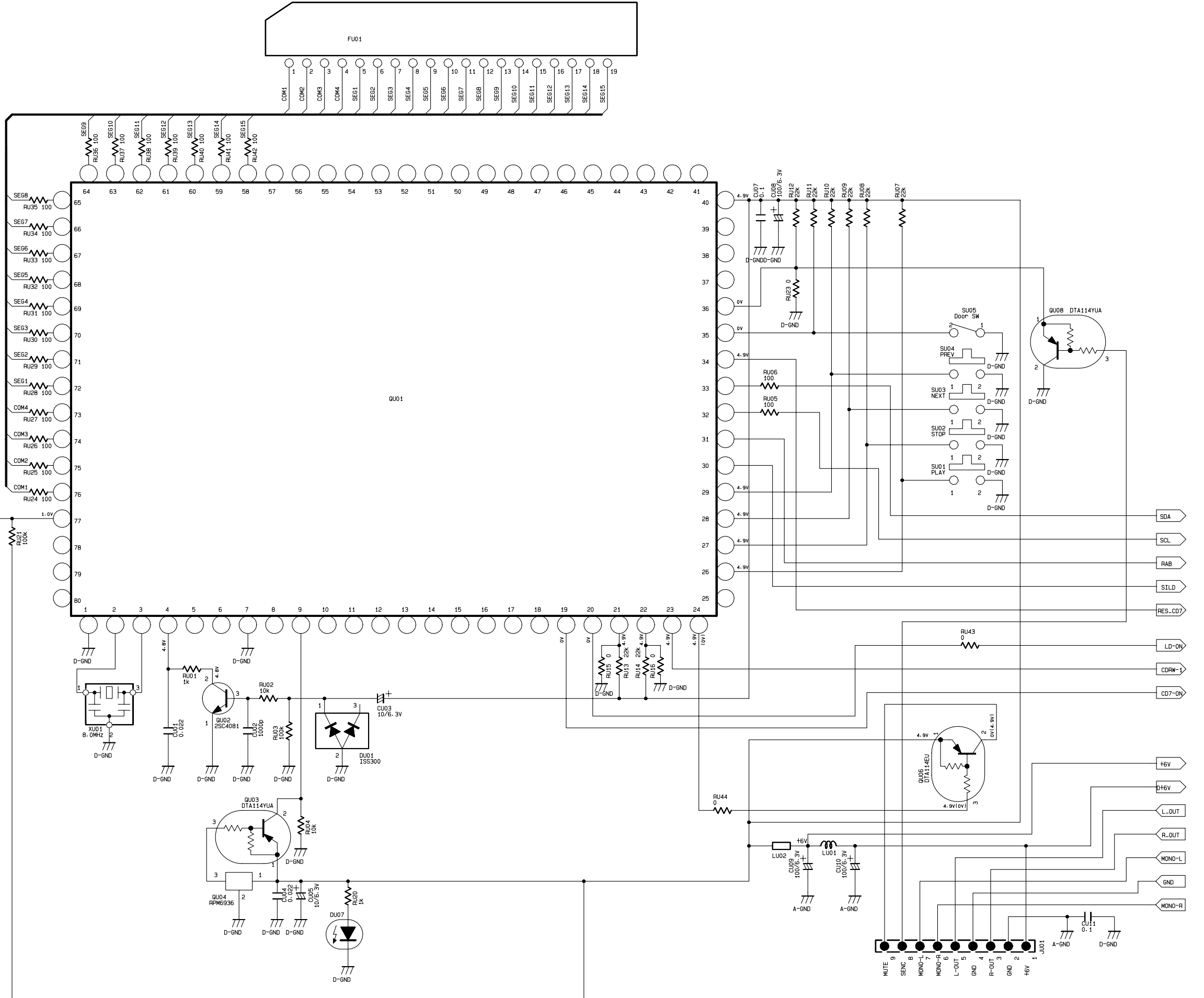
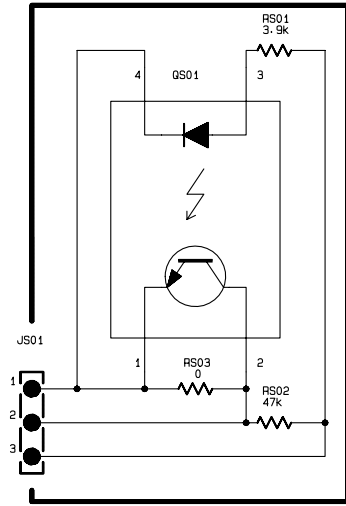

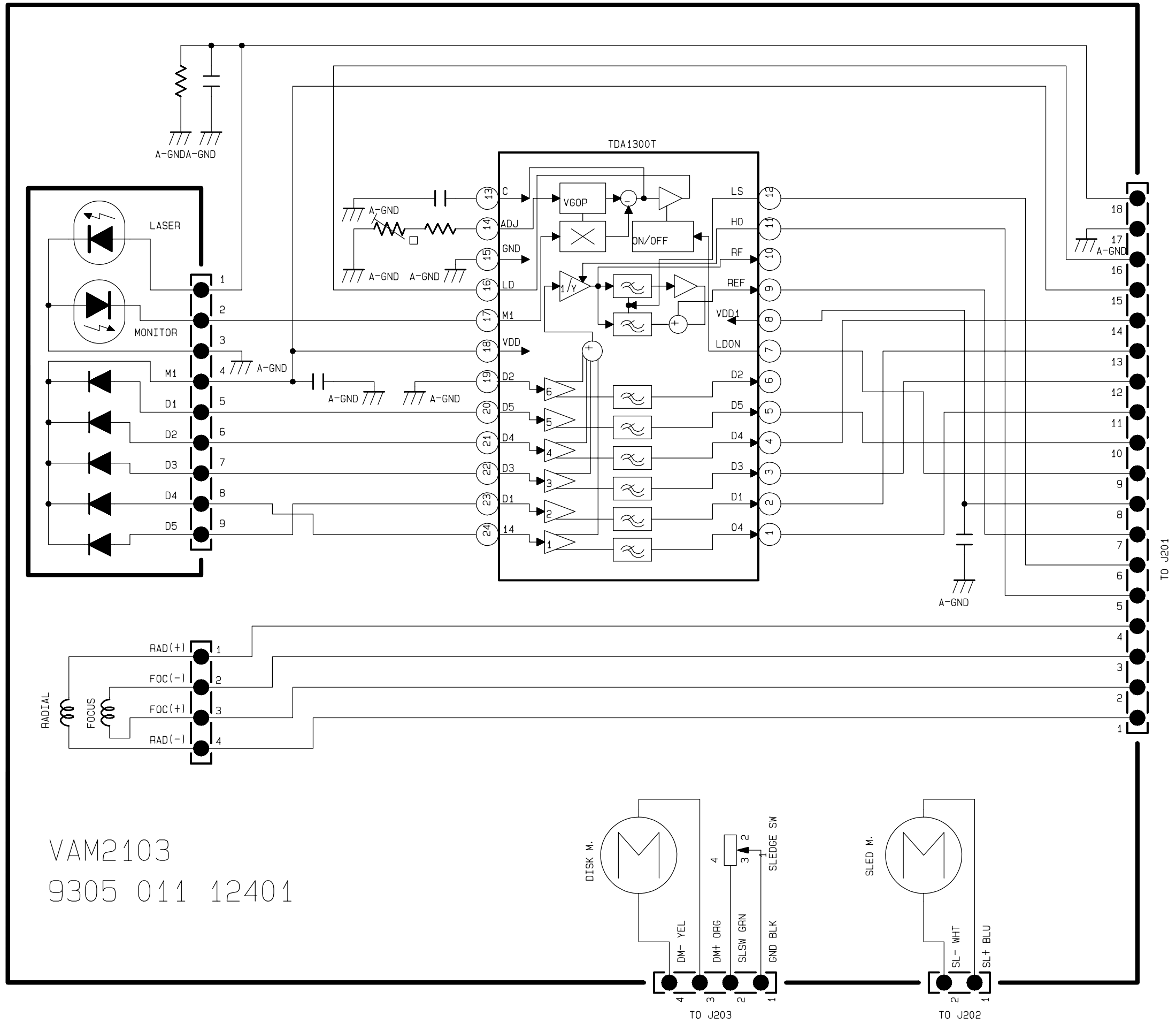

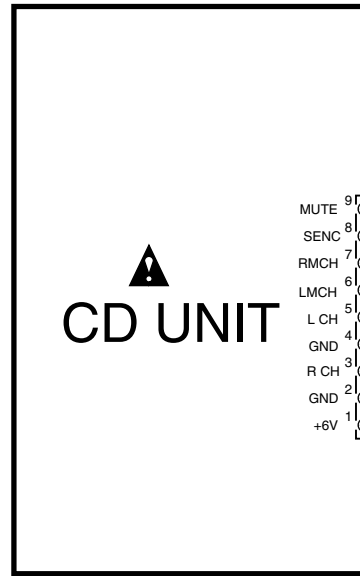

- ➡ L CH
- ➡ R CH
- ▷ AUDIO OUT L CH
- ▷ AUDIO OUT R CH

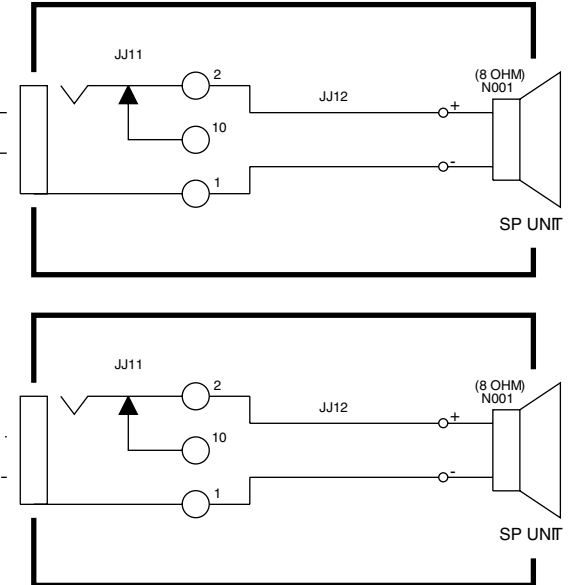
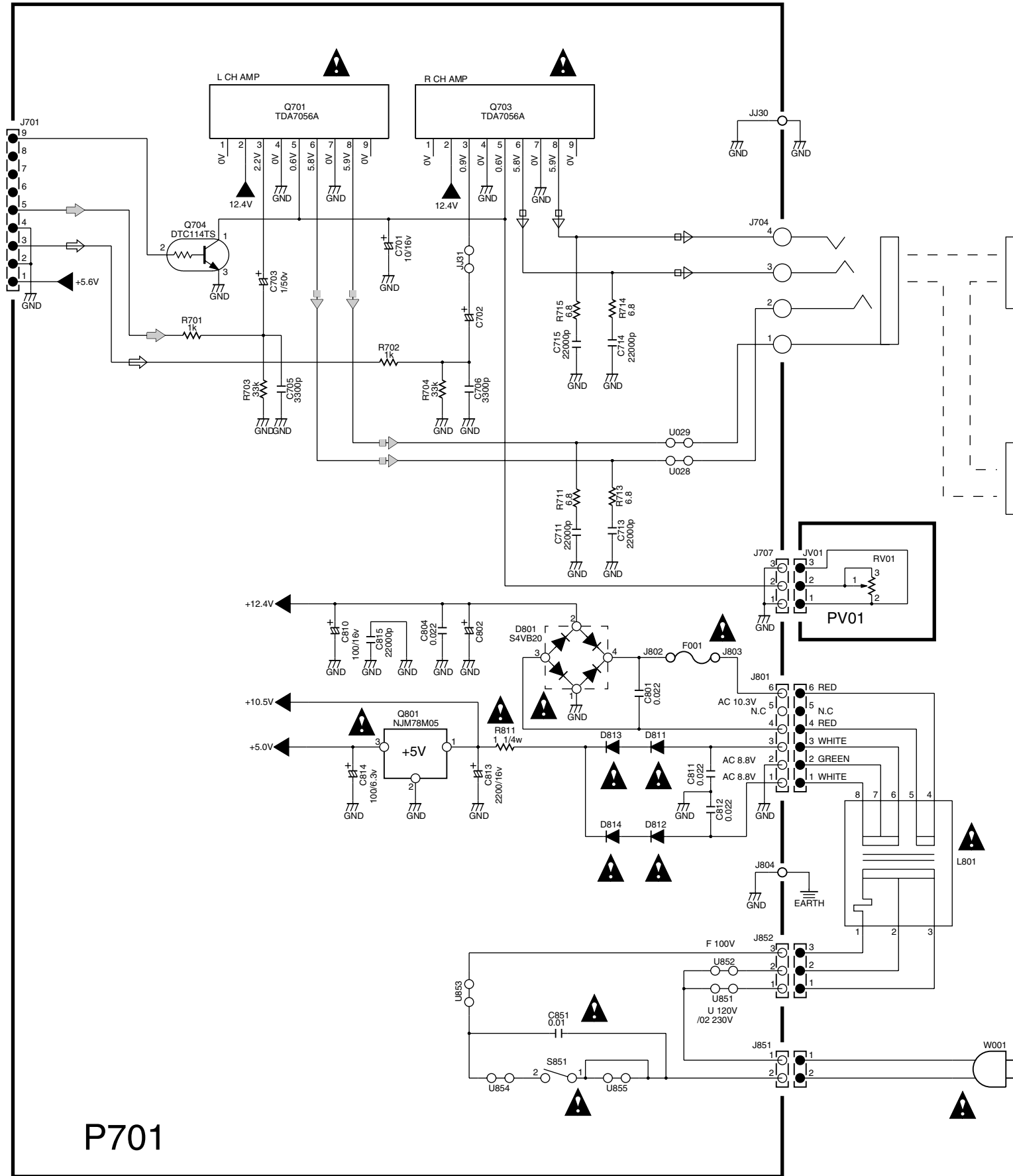

C802	
F,U	3300UF/16V
/02,K,KK	2200UF/25V

F001	
F,U	3.15A/125V
/02,K,KK	T2.5A/250V

L801 PRI. WIRE COLOR			
	1	2	3
F,U	WHITE	BROWN	RED
/02,K,KK	BLUE	RED	BROWN

5. PARTS LOCATION (Component Side)

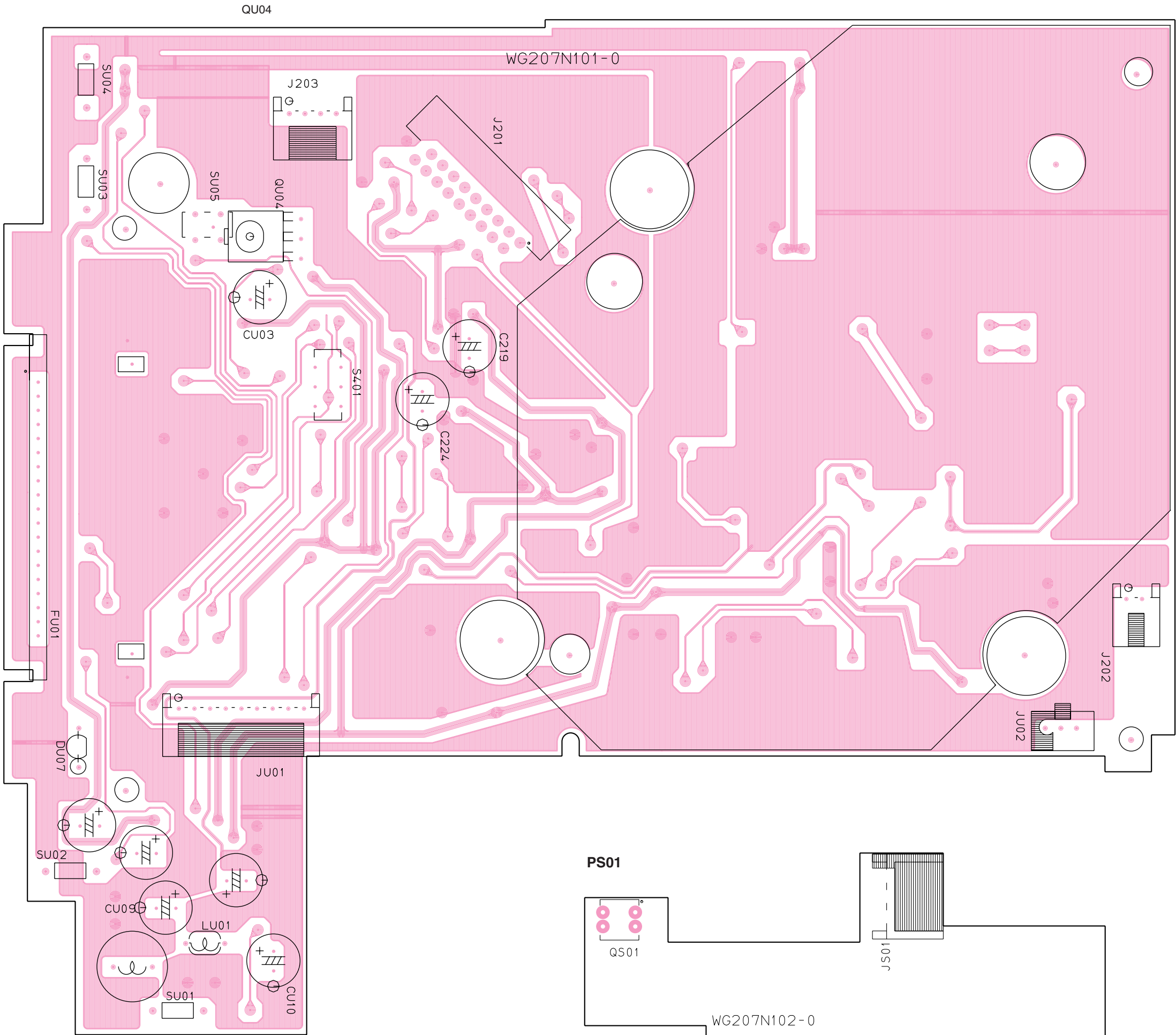

PARTS LOCATION (Solder Side)

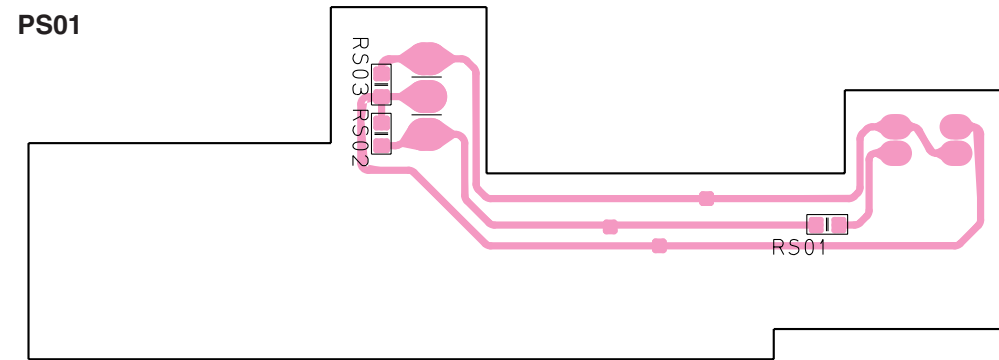
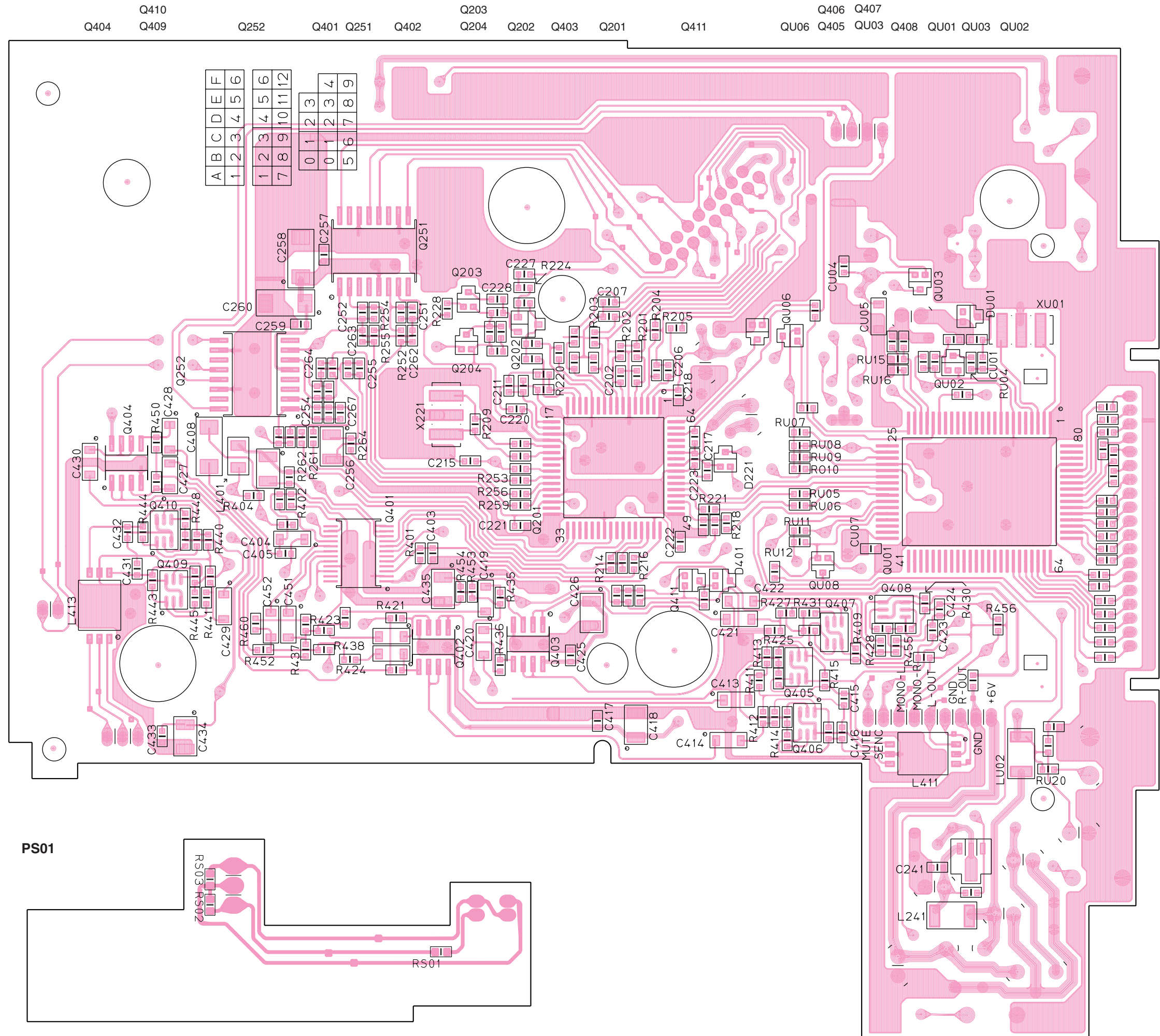

6. IC DATA
Q251/252:TDA7073A

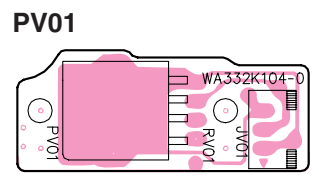
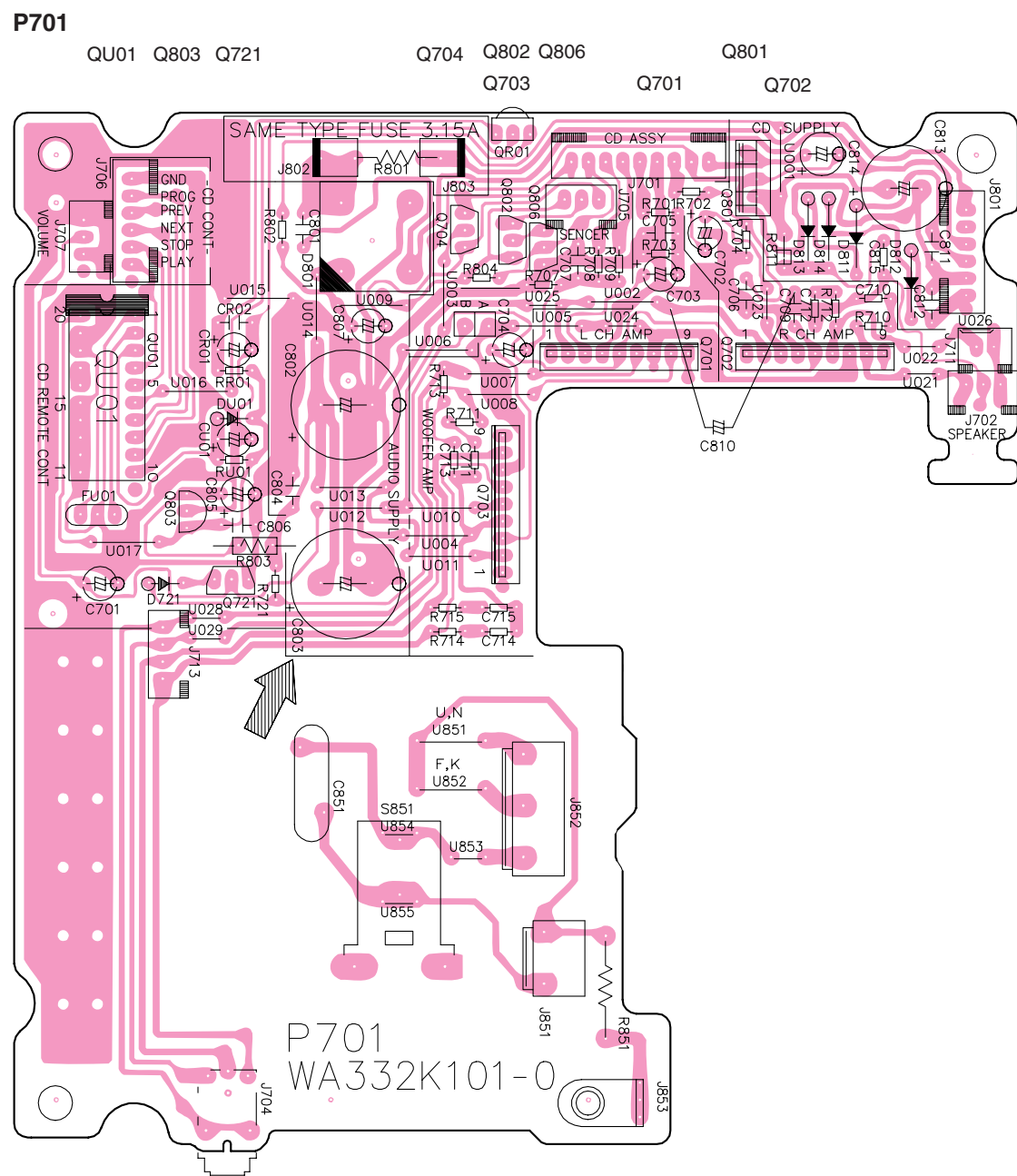

Block Diagram

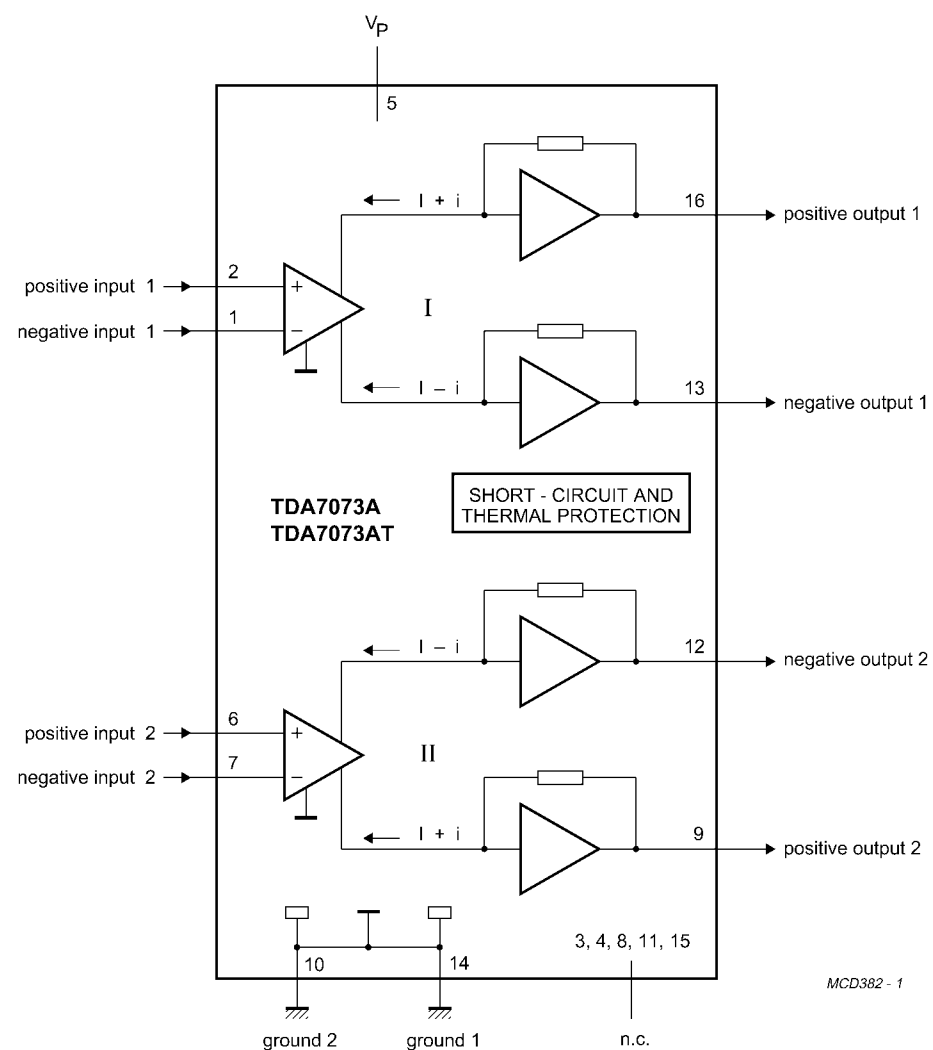

Pinning

SYMBOL	PIN	DESCRIPTION
IN1-	1	negative input 1
IN1+	2	positive input 1
n.c.	3	not connected
n.c.	4	not connected
V _P	5	positive supply voltage
IN2+	6	positive input 2
IN2-	7	negative input 2
n.c.	8	not connected
OUT2+	9	positive output 2
GND2	10	ground 2
n.c.	11	not connected
OUT2-	12	negative output 2
OUT1-	13	negative output 1
GND1	14	ground 1
n.c.	15	not connected
OUT1+	16	positive output 1

Pin Configuration

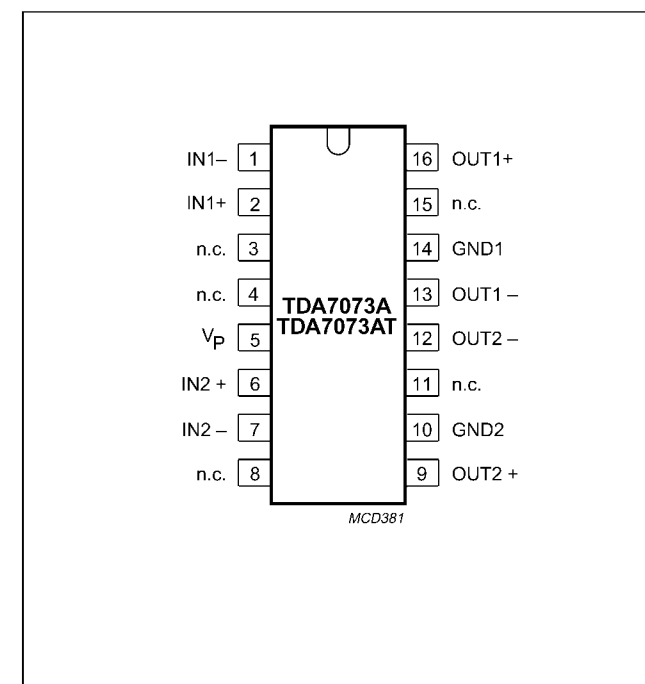

Block Diagram

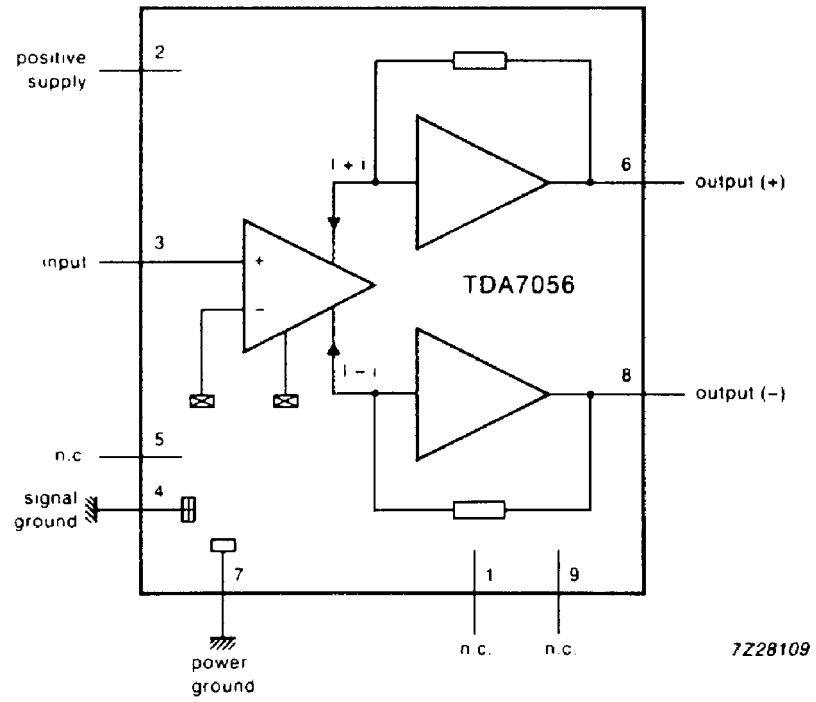

☒ = low current ground

☒ = signal ground

Pinning

PIN	DESCRIPTION
1	n.c.
2	V_P
3	input (+)
4	signal ground
5	n.c.
6	output (+)
7	power ground
8	output (-)
9	n.c.

Block Diagram

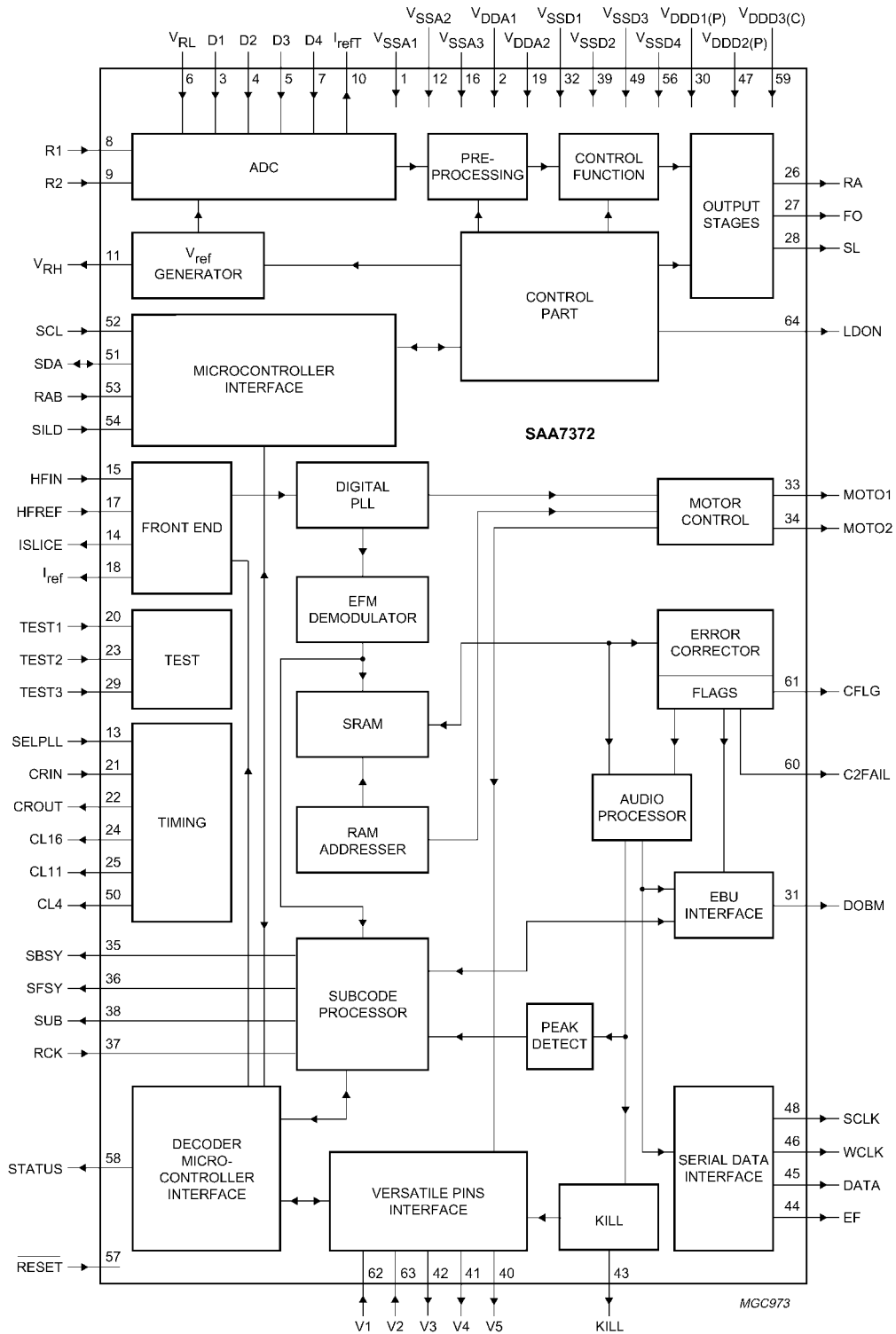

SYMBOL	PIN	DESCRIPTION
V _{SSA1}	1 ⁽¹⁾	analog ground 1
V _{DDA1}	2 ⁽¹⁾	analog supply voltage 1
D1	3	unipolar current input (central diode signal input)
D2	4	unipolar current input (central diode signal input)
D3	5	unipolar current input (central diode signal input)
V _{RL}	6	reference voltage input for ADC
D4	7	unipolar current input (central diode signal input)
R1	8	unipolar current input (satellite diode signal input)
R2	9	unipolar current input (satellite diode signal input)
I _{refT}	10	current reference output for ADC calibration
V _{RH}	11	reference voltage output from ADC
V _{SSA2}	12 ⁽¹⁾	analog ground 2
SELPLL	13	selects whether internal clock multiplier PLL is used
ISLICE	14	current feedback output from data slicer
HFIN	15	comparator signal input
V _{SSA3}	16 ⁽¹⁾	analog ground 3
HFREF	17	comparator common mode input
I _{ref}	18	reference current output pin (nominally 0.5V _{DD})
V _{DDA2}	19 ⁽¹⁾	analog supply voltage 2
TEST1	20	test control input 1; this pin should be tied LOW
CRIN	21	crystal/resonator input
CROUT	22	crystal/resonator output
TEST2	23	test control input 2; this pin should be tied LOW
CL16	24	16.9344 MHz system clock output
CL11	25	11.2896 or 5.6448 MHz clock output (3-state)
RA	26	radial actuator output
FO	27	focus actuator output
SL	28	sledge control output
TEST3	29	test control input 3; this pin should be tied LOW
V _{DD1(P)}	30 ⁽¹⁾	digital supply voltage 1 for periphery
DOBM	31	bi-phase mark output (externally buffered; 3-state)
V _{SSD1}	32 ⁽¹⁾	digital ground 1
MOTO1	33	motor output 1; versatile (3-state)
MOTO2	34	motor output 2; versatile (3-state)
SBSY	35	subcode block sync output (3-state)
SFSY	36	subcode frame sync output (3-state)
RCK	37	subcode clock input
SUB	38	P-to-W subcode output bits (3-state)
V _{SSD2}	39 ⁽¹⁾	digital ground 2
V5	40	versatile output pin 5
V4	41	versatile output pin 4
V3	42	versatile output pin 3 (open-drain)
KILL	43	kill output (programmable; open-drain)
EF	44	C2 error flag; output only defined in CD ROM modes and 1f _s modes (3-state)
DATA	45	serial data output (3-state)
WCLK	46	word clock output (3-state)
V _{DD2(P)}	47 ⁽¹⁾	digital supply voltage 2 for periphery
SCLK	48	serial bit clock output (3-state)
V _{SSD3}	49 ⁽¹⁾	digital ground 3
CL4	50	4.2336 MHz microcontroller clock output
SDA	51	microcontroller interface data I/O line (open-drain output)
SCL	52	microcontroller interface clock line input
RAB	53	microcontroller interface R/W and load control line input (4-wire bus mode)
SILD	54	microcontroller interface R/W and load control line input (4-wire-bus mode)
n.c.	55	not connected
V _{SSD4}	56 ⁽¹⁾	digital ground 4
RESET	57	power-on reset input (active LOW)
STATUS	58	servo interrupt request line/decoder status register output (open-drain)
V _{DD3(C)}	59 ⁽¹⁾	digital supply voltage 3 for core
C2FAIL	60	indication of correction failure output (open-drain)
CFLG	61	correction flag output (open-drain)
V1	62	versatile input pin 1
V2	63	versatile input pin 2
LDON	64	laser drive on output (open-drain)

Note

1. All supply pins must be connected to the same external power supply voltage.

Block Diagram

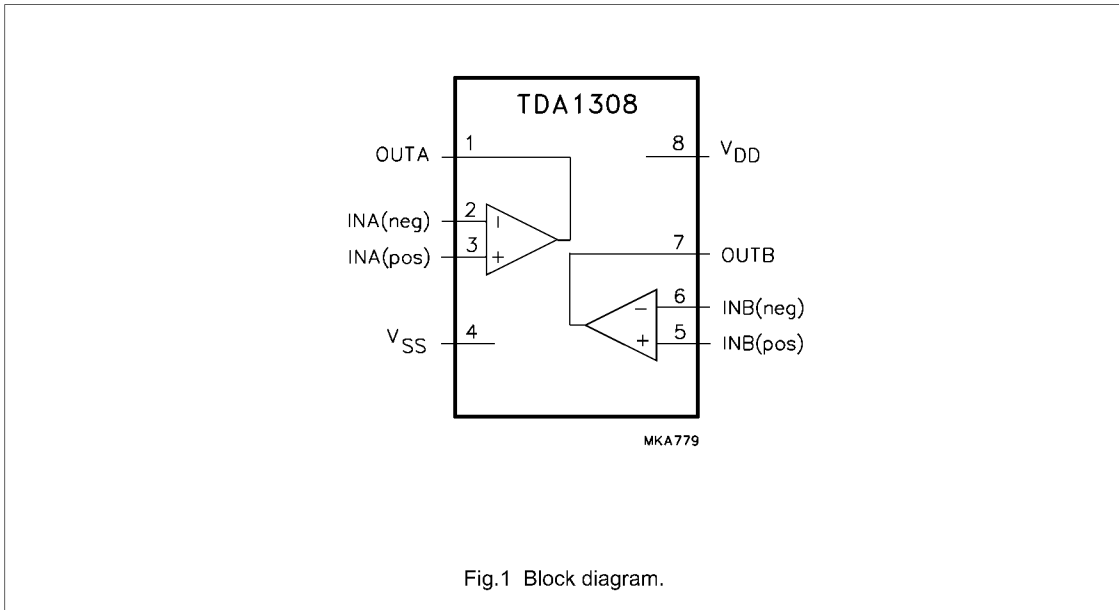

Pinning

SYMBOL	PIN	DESCRIPTION
OUTA	1	output A
INA(neg)	2	inverting input A
INA(pos)	3	non-inverting input A
V _{SS}	4	negative supply
INB(pos)	5	non-inverting input B
INB(neg)	6	inverting input B
OUTB	7	output B
V _{DD}	8	positive supply

Pin Configuration

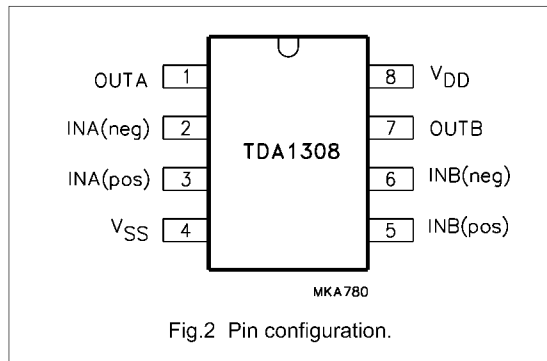

Pin Assignment

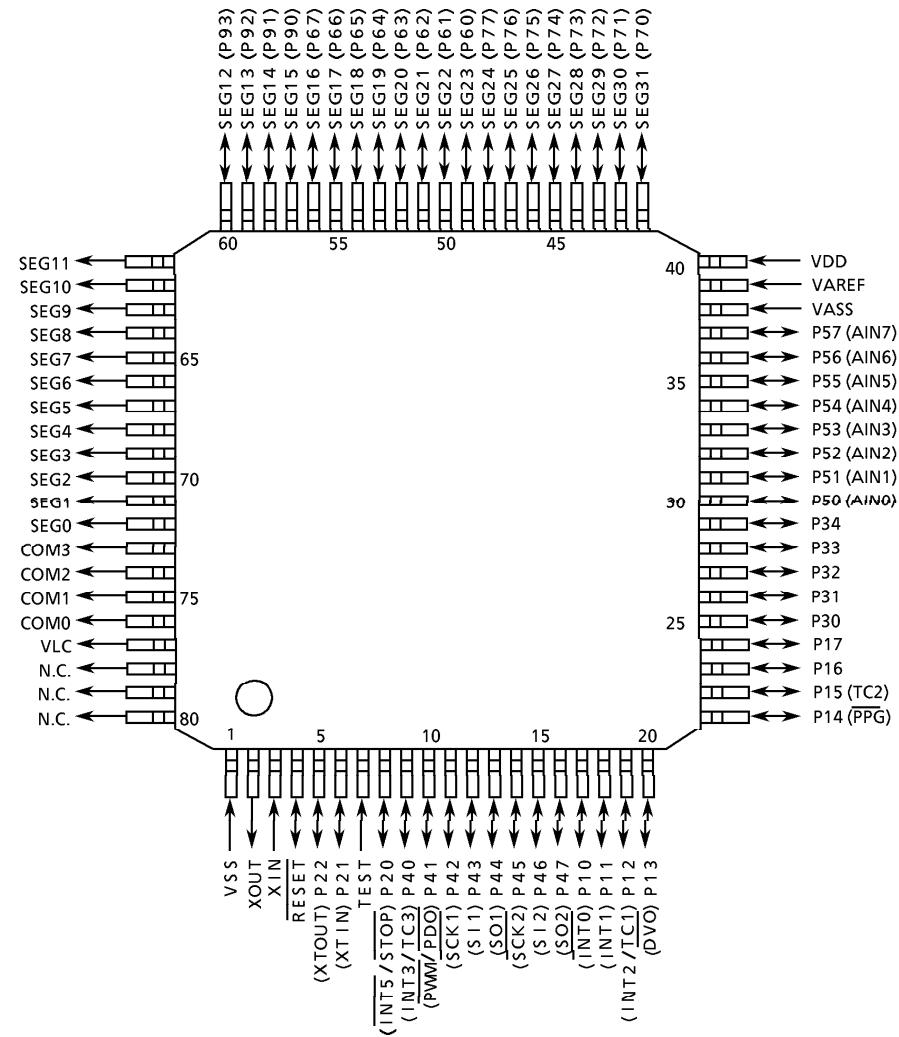

Pin Function

No	Name	Function	I/O	Purpose
1	Vss	GND	-	GND
2	XOUT	Crystal	O	8MHz
3	XIN	Crystal	I	8MHz
4	RESET	Active (L)	I	Reset Mi-Com
5	P22/XTOUT		I/O	
6	P21/XTIN		I/O	
7	TEST	TEST	I	GND
8	P20/INT5/STOP	3Bits I/O Port	I/O	
9	P40/INT3/TC3	8Bits I/O Port	I/O	IR-IN
10	P41/PWM/PDO	8Bits I/O Port	I/O	
11	P42/SCK1	8Bits I/O Port	I/O	
12	P43/SI1	8Bits I/O Port	I/O	
13	P44/SO1	8Bits I/O Port	I/O	
14	P45/SCK2	8Bits I/O Port	I/O	
15	P46/SI2	8Bits I/O Port	I/O	
16	P47/SO2	8Bits I/O Port	I/O	
17	P10/INT0	8Bits Programmable I/O Port	I/O	
18	P11/INT1	8Bits Programmable I/O Port	I/O	
19	P12/INT2/TC1	8Bits Programmable I/O Port	O	CD Module Power On/Off
20	P13/DVO	8Bits Programmable I/O Port	O	Laser On/Off
21	P14/PPG	8Bits Programmable I/O Port	I	Play Mode b1
22	P15/TC2	8Bits Programmable I/O Port	I	Play Mode b2
23	P16	8Bits Programmable I/O Port	O	CD-RW (L)
24	P17	8Bits Programmable I/O Port	O	MUTE

No	Name	Function	I/O	Purpose
25	P30	5Bits I/O Port	I/O	
26	P31	5Bits I/O Port	I/O	PLAY
27	P32	5Bits I/O Port	I/O	STOP
28	P33	5Bits I/O Port	I/O	NEXT
29	P34	5Bits I/O Port	I/O	PREV
30	P50/AIN0	8Bits Programmable I/O Port	I/O	CD Module SILD
31	P51/AIN1	8Bits Programmable I/O Port	I/O	CD Module RAB
32	P52/AIN2	8Bits Programmable I/O Port	I/O	CD Module SCL
33	P53/AIN3	8Bits Programmable I/O Port	I/O	CD Module SDA
34	P54/AIN4	8Bits Programmable I/O Port	I/O	CD Module RES. CD7
35	P55/AIN5	8Bits Programmable I/O Port	I/O	Door SW
36	P56/AIN6	8Bits Programmable I/O Port	I/O	SENC
37	P57/AIN7	8Bits Programmable I/O Port	I/O	
38	VASS	Reference GND	I	
39	VAREF	Reference Voltage for A/D Conversion	I	
40	VDD	GND	I	
41	SEG31/P70		I/O	
42	SEG30/P71		I/O	
43	SEG29/P72		I/O	
44	SEG28/P73		I/O	
45	SEG27/P74		I/O	
46	SEG26/P75		I/O	
47	SEG25/P76		I/O	
48	SEG24/P77		I/O	
49	SEG23/P60		I/O	
50	SEG22/P61		I/O	
51	SEG21/P62		I/O	
52	SEG20/P63		I/O	
53	SEG19/P64		I/O	
54	SEG18/P65		I/O	
55	SEG17/P66		I/O	
56	SEG16/P67		I/O	
57	SEG15/P90		I/O	
58	SEG14/P91	CAR, JAZZ, ROCK, Battery-B	I/O	
59	SEG13/P92	6a, 6b, 6c, Battery-A	I/O	
60	SEG12/P93	6d, 6e, 6f, 6g	I/O	
61	SEG11	5a, 5b, 5c, REPEAT	O	
62	SEG10	5d, 5e, 5f, 5g	O	
63	SEG9	4a, 4b, 4c, :	O	
64	SEG8	4d, 4e, 4f, 4g	O	
65	SEG7	3a, 3b, 3c, PROGRAM	O	
66	SEG6	3d, 3e, 3f, 3g	O	
67	SEG5	2a, 2b, 2c, RESUME	O	
68	SEG4	2d, 2e, 2f, 2g	O	
69	SEG3	1a, 1b, 1c, SHUFFLE	O	
70	SEG2	1d, 1e, 1f, 1g	O	
71	SEG1	L, R	O	
72	SEG0	VIDEO, PBC, KARAOKE	O	
73	COM3		O	
74	COM2		O	
75	COM1		O	
76	COM0		O	
77	VLC	LCD Power	O	VDD-VLC=3V
78	N.C.		O	
79	N.C.		O	
80	N.C.		O	

8. EXPLODED VIEW AND PARTS LIST

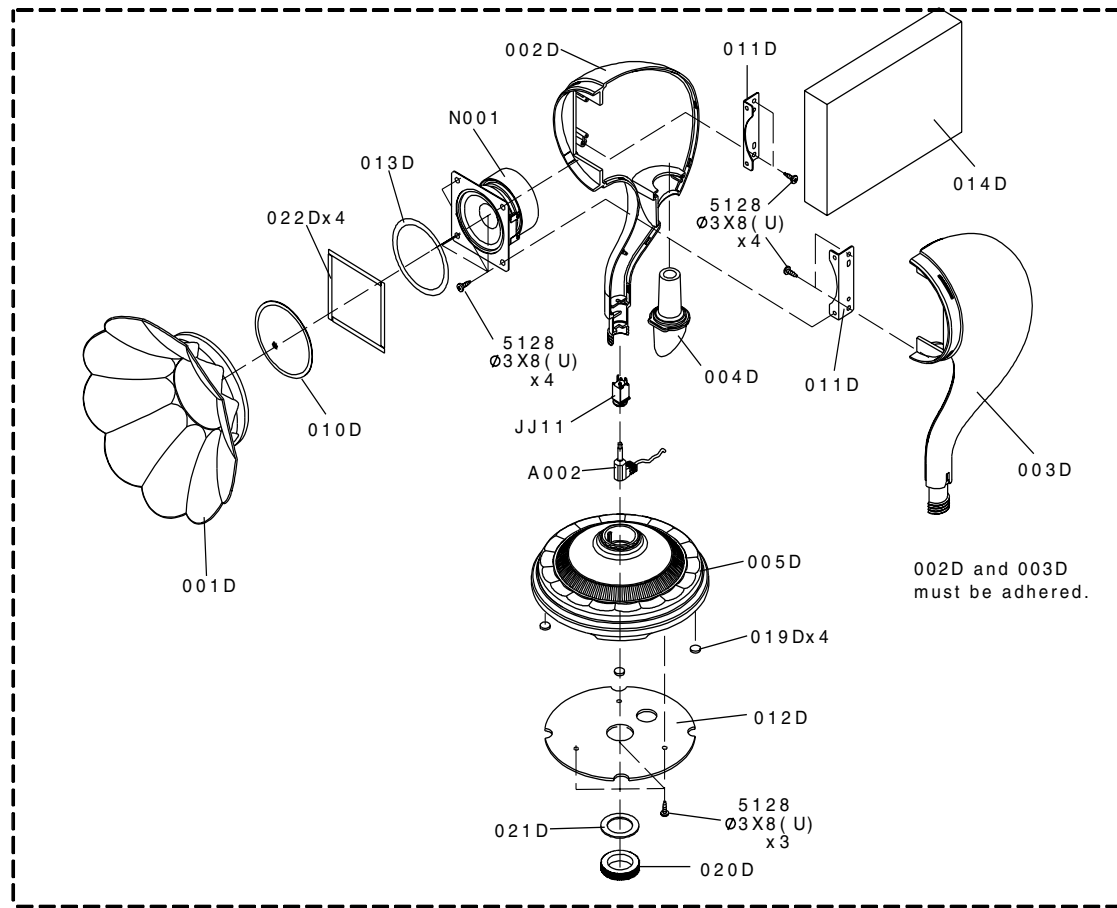

SYMBOL	STYLE	PARTS NAME
5110		+B. H. M. SCREW
5128		+B. H. TAP TITE SCREW(B TYPE)
5159		+B. H. TAP TITE SCREW(S TYPE)

MARK	MATERIAL/ FINISH
(A)	STEEL/ COPPER
(U)	STEEL/ BLACK

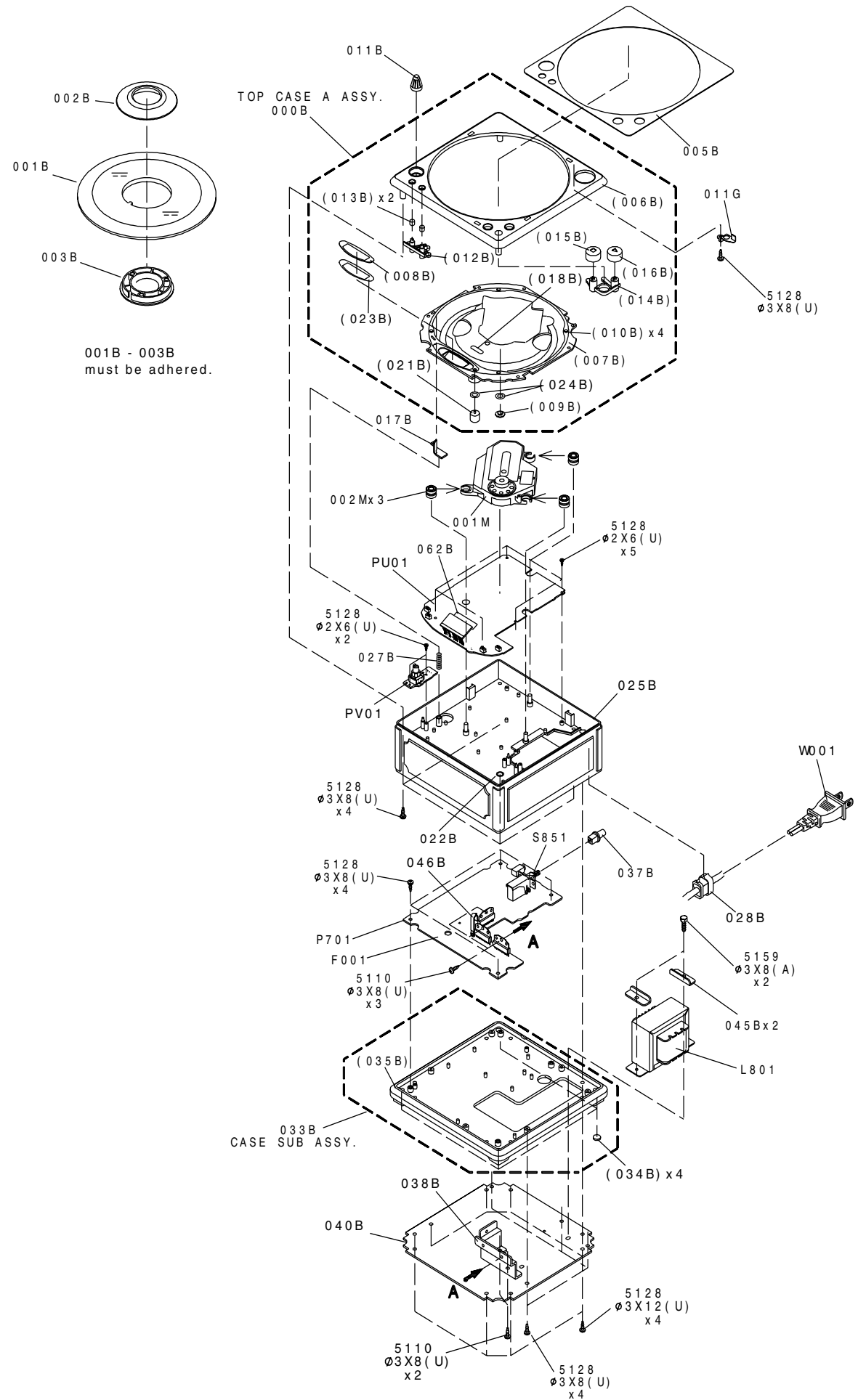

POS. NO	VERS. COLOR	PART NO. (FOR PCS)	DESCRIPTION	PART NO. (MJI)	POS. NO	VERS. COLOR	PART NO. (FOR PCS)	DESCRIPTION	PART NO. (MJI)
000B			CASE A SUB ASSY (P.WHITE)	207N064510				PACKING USER GUIDE CONNECT CORD, MONO MINI JACK 4P	
001B			LID DIS (CLEAR)	332K257020	001T				352K851110
002B			BUSH-UP (P.WHITE)	332K067330	A002				ZD01505020
003B			BUSHING, -DOWN (P.WHITE CLEAR LID)	332K259310					
005B			ESCUTCHEON, SHEET (P.WHITE)	332K063350					
006B			CASE, TOP COVER (CD) P.WHITE	nsp					
007B			TRAY (CD)	nsp					
008B			WINDOW LCD	nsp					
009B			SENSOR LENS	nsp					
010B			LEG, BUFFER FOR LID	nsp					
011B			VOLUME KNOB (WHITE)	332K154310					
012B			HINGE BUTTON (SKIP)	nsp					
013B			SILVER FOR BUTTON SKIP	nsp					
014B			HINGE BUTTON (PLAY/STOP)	nsp					
015B			SILVER FOR 014B (STOP)	nsp					
016B			SILVER FOR 014B (PLAY)	nsp					
017B			LEAF BUTTON	332K270030					
018B			MASK	nsp					
021B			LED LENS	nsp					
022B			SPACER, (TOP CASE FRONT R SIDE)	nsp					
023B			STICKER, ADHESIVE FOR WINDOW	nsp					
024B			STICKER, ADHESIVE FOR LENS (2 TYPE)	nsp					
025B			CASE, (CD) P.WHITE	332K064050					
027B			COIL SPRING	332K115010					
028B		4822 532 60948	AC CORD BUSH (2271)	450H259010					
033B			CASE A2 SUB ASSY (P.WHITE)	332K064650					
034B			LEG (BUFFER)	nsp					
037B		4822 410 60343	BUTTON, POWER KNOB	058J270030					
038B			HEAT SINK	nsp					
040B			BOTTOM WEIGHT T=1.6BLACK	207N008010					
062B			LCD HOLDER	323K271010					
001D			HORN RING (P.WHITE)	352K353110					
002D			HORN STAND L(P.WHITE)	352K128110					
003D			HORN STAND R(P.WHITE)	352K128120					
004D			COLLAR AIR (P.WHITE)	352K055110					
005D			STAND TABLE (WHITE)	352K004110					
010D			PUNCHING NET (WHITE)	352K202110					
011D			SPK BRACKET	352K160010					
013D			INSULATOR FOR PROTECTOR	nsp					
014D			PROTECTOR, SILENCER	nsp					
019D			LEG CUSHION	332K057010					
020D			NUT	nsp					
021D			RUBBER RING	nsp					
022D			INSULATOR, PEF SHEET 4X58	nsp					
011G			CONTACTOR	nsp					
001M			CD MECHA(VAM2103)	452S304500					
002M		4822 402 10897	BUFFER, DAMPER	359K056010					
JJ11			3.5 MONO JACK HSJ1400-01-010	YJ01004530					
▲ L801			MAINSTRANS 100V/120V	TS15750010					
N001			SPEAKER, 5CM 8Ω 5W	QK00502090					
▲ W001			A.C MAINS CORD	YC01900270					
							NOT STANDARD SPARE PARTS		
					001S		PACKING CASE, ED-5 (1 COLOR)	352K801110	
					002S		CUSHION, L&R	352K809010	

NOTE : "nsp" PART IS LISTED FOR REFERENCE ONLY, MARANTZ WILL NOT SUPPLY THESE PARTS.

8. ELECTRICAL PARTS LIST

ASSIGNMENT OF COMMON PARTS CODES.

RESISTORS

R***: 1) GD05 × × × 140, Carbon film fixed resistor, ±5% 1/4W
 R***: 2) GD05 × × × 160, Carbon film fixed resistor, ±5% 1/6W

① — Resistance value

Examples ;

① Resistance value
 0.1 Ω ... 001 10 Ω ... 100 1 kΩ ... 102 100 kΩ ... 104
 0.5 Ω ... 005 18 Ω ... 180 2.7 kΩ ... 272 680 kΩ ... 684
 1 Ω ... 010 100 Ω ... 101 10 kΩ ... 103 1 MΩ ... 105
 6.8 Ω ... 068 390 Ω ... 391 22 kΩ ... 223 4.7 MΩ ... 475

Note : Please distinguish 1/4W from 1/6W by the shape of parts used actually.

CAPACITORS

C***: CERAMIC CAP.

3) DD1 × × × × 370, Ceramic capacitor
 Disc type
 Temp.coeff.P350 ~ N1000, 50V
 ② — Capacity value
 ③ — Tolerance

Examples ;

② Tolerance (Capacity deviation)
 ±0.25 pF ... 0
 ±0.5 pF ... 1
 ±5% ... 5

* Tolerance of COMMON PARTS handled here are as follows :

0.5 pF ~ 5 pF ... ±0.25 pF
 6 pF ~ 10 pF ... ±0.5 pF
 12 pF ~ 560 pF ... ±5%

③ Capacity value

0.5 pF ... 005 3 pF ... 030 100 pF ... 101
 1 pF ... 010 10 pF ... 100 220 pF ... 221
 1.5 pF ... 015 47 pF ... 470 560 pF ... 561

C*** : CERAMIC CAP.

4) DK16 × × × × 300, High dielectric constant ceramic capacitor
 Disc type
 Temp.chara. 2B4, 50V
 ④ — Capacity value

Examples ;

④ Capacity value
 100 pF ... 101 1000 pF ... 102 10000 pF ... 103
 470 pF ... 471 2200 pF ... 222

C*** : 5) ELECTROLY CAP. (⏏), 6) FILM CAP. (⏏)

5) EA × × × × × 10, Electrolytic capacitor
 One-way lead type, Tolerance ±20%
 ⑤ — Working voltage
 ⑥ — Capacity value

Examples ;

⑤ Capacity value
 0.1 μF ... 104 4.7 μF ... 475 100 μF ... 107
 0.33 μF ... 334 10 μF ... 106 330 μF ... 337
 1 μF ... 105 22 μF ... 226 1100 μF ... 118
 2200 μF ... 228

⑥ Working voltage

6.3V ... 006 25V ... 025
 10V ... 010 35V ... 035
 16V ... 016 50V ... 050

6) DF15 × × × 350 — Plastic film capacitor
 DF15 × × × 310 — One-way type, Mylar ±5% 50V
 DF16 × × × 310 — Plastic film capacitor
 One-way type, Mylar ±10% 50V
 ⑦ — Capacity value

Examples ;

⑦ Capacity value
 0.001 μF (1000 pF) ... 102 0.1 μF ... 104
 0.0018 μF ... 182 0.56 μF ... 564
 0.01 μF ... 103 1 μF ... 105
 0.015 μF ... 153

NOTE : 1) The above CODES (R***, R***, C***, C*** and C***) are omitted on the schematic diagram in some case.

2) On the occasion, be confirmed the common parts on the parts list.

3) Refer to "Common Parts List" for the other common parts (R105, DD4, DK4).

NOTE ON SAFETY FOR FUSIBLE RESISTOR :

The suppliers and their type numbers of fusible resistors are as follows;

1. KOA Corporation

Part No. (MJI)	Type No. (KOA)	Description
NH05 × × × 140	RF25S × × × × ΩJ	(±5% 1/4W)
NH05 × × × 120	RF50S × × × × ΩJ	(±5% 1/2W)
NH85 × × × 110	RF73B2A × × × × ΩJ	(±5% 1/10W)
NH95 × × × 140	RF73B2E × × × × ΩJ	(±5% 1/4W)

* Resistance value * Resistance value
 (0.1 Ω – 10 kΩ)

2. Matsushita Electronic Components Co., Ltd

Part No. (MJI)	Type No. (MEC)	Description
NF05 × × × 140	ERD-2FCJ × × ×	(±5% 1/4W)
RF05 × × × 140		
NF02 × × × 140	ERD-2FCG × × ×	(±2% 1/4W)
RF02 × × × 140		

* Resistance value * Resistance value

Examples ;

* Resistance value
 0.1 Ω ... 001 10 Ω ... 100 1 kΩ ... 102 100 kΩ ... 104
 0.5 Ω ... 005 18 Ω ... 180 2.7 kΩ ... 272 680 kΩ ... 684
 1 Ω ... 010 100 Ω ... 101 10 kΩ ... 103 1 MΩ ... 105
 6.8 Ω ... 068 390 Ω ... 391 22 kΩ ... 223 4.7 MΩ ... 475

ABBREVIATION AND MARKS

ANT. : ANTENNA	BATT. : BATTERY
CAP. : CAPACITOR	CER. : CERAMIC
CONN. : CONNECTING	DIG. : DIGITAL
HP : HEADPHONE	MIC. : MICROPHONE
μ-PRO : MICROPROCESSOR	REC. : RECORDING
RES. : RESISTOR	SPK : SPEAKER
SW : SWITCH	TRANSF. : TRANSFORMER
TRIM. : TRIMMING	TRS. : TRANSISTOR
VAR. : VARIABLE	X'TAL : CRYSTAL

NOTE ON FUSE :

Regarding to all parts of parts code **FS20xxx2xx**, replace only with Wickmann-Werke GmbH, Type 372 non glass type fuse.

NOTE ON SAFETY :

Symbol \blacktriangle Fire or electrical shock hazard. Only original parts should be used to replaced any part marked with symbol \blacktriangle . Any other component substitution (other than original type), may increase risk of fire or electrical shock hazard.

安全上の注意 :

\blacktriangle がついている部品は、安全上重要な部品です。必ず指定されている部品番号の部品を使用して下さい。

POS. NO	VERS. COLOR	PART NO. (FOR PCS)	DESCRIPTION	PART NO. (MJ)	POS. NO	VERS. COLOR	PART NO. (FOR PCS)	DESCRIPTION	PART NO. (MJ)
			P701-POWER SUPPLY, AMP CIRCUIT BOARD						
			P701-CAPACITORS						
C701		4822 124 80395	ELECT., 10µF/16V	EA10601620	C218		4822 126 11687	CER.CHIP, 0.1µF	DK98104200
C702		4822 124 22776	ELECT., 1µF/50V	EA10505020	C219		4822 124 21901	ELECT., 47µF/6.3V	EJ47600610
C703		4822 124 22776	ELECT., 1µF/50V	EA10505020	C220				
C711							4822 126 11687	CER.CHIP, 0.1µF	DK98104200
}		4822 122 40588	CER., 0.022µF	DA17223110	C223				
C715					C224		4822 124 21901	ELECT., 47µF/6.3V	EJ47600610
C801		4822 122 30103	CER., 0.022µF +80%-20% 50V	DK18223310	C226		4822 126 12339	CER.CHIP, 2200pF ±10%	DK96222300
C802		4822 124 90388	ELECT., 3300µF 16V RA2 TYPE	OA33801620	C227			CER.CHIP, 0.22µF	DK98224200
C803		4822 124 90388	ELECT., 3300µF 16V RA2 TYPE	OA33801620	C228		4822 126 14249	CER.CHIP, W5R 560pF	DK96561300
C804		4822 122 30103	CER., 0.022µF +80%-20% 50V	DK18223310	C229		4822 126 11759	CER.CHIP, 100pF ±5% 50V	DD95101300
C810			ELECT., 100µF/16V	EA107016P0	C241		4822 126 11687	CER.CHIP, 0.1µF	DK98104200
C811		4822 122 30103	CER., 0.022µF +80%-20% 50V	DK18223310	C242		4822 126 10935	ELECT., 100µF/6.3V	EJ10700610
C812		4822 122 30103	CER., 0.022µF +80%-20% 50V	DK18223310	C251		4822 126 11685	CER.CHIP, 4700pF ±10% 50V	DK96472300
C813		4822 124 40723	ELECT., 2200µF ±20% 16V	OA22801620	C252		4822 126 11685	CER.CHIP, 4700pF ±10% 50V	DK96472300
C814		4822 126 10935	ELECT., 100µF 6.3V	EJ10700610	C253				
C815		4822 122 40588	CER., 0.022µF	DA17223110	}		4822 126 11687	CER.CHIP, 0.1µF	DK98104200
▲ C851		4822 122 33276	CER., SPERK KILLER 0.01µF	DK17103840	C255				
			P701-CAPACITORS (COMMON)		C256		4822 124 11495	TANTL.CHIP, 47µF/6.3V	EY47600650
			FILM 0.001µF 50V : C705, C706		C257		4822 126 11687	CER.CHIP, 0.1µF	DK98104200
			P701-RESISTORS		C258		9965 000 03906	TANTL.CHIP, 100µF/6.3V	EY10700670
▲ R811		4822 116 60307	FUSIBLE CHIP, 1Ω ±5% 1/4W	NH05010140	C259		4822 126 11687	CER.CHIP, 0.1µF	DK98104200
			P701-RESISTORS (COMMON)		C261		4822 126 10935	ELECT., 100µF/6.3V	EJ10700610
			RES. 1kΩ ±5% 1/6W :		C262		4822 126 11568	CER.CHIP, 470pF (GR39)	DK96471300
			R701, R702		C263		4822 126 11568	CER.CHIP, 470pF (GR39)	DK96471300
			RES. 33kΩ ±5% 1/6W :		C264				
			R703, R704		}		4822 126 11687	CER.CHIP, 0.1µF	DK98104200
			RES. 15Ω ±5% 1/6W :		C401				
			R711, R713-R715		C402		4822 124 11495	TANTL.CHIP, 47µF/6.3V	EY47600650
			P701-SEMICONDUCTORS		C403		4822 126 11687	CER.CHIP, 0.1µF	DK98104200
▲ D801		4822 130 31007	DIODE, DIODE S4VB	HE20015290	C404		4822 124 11383	TANTL.CHIP, 10µF/6.3V	EY10600650
▲ D811					C405		4822 126 11687	CER.CHIP, 0.1µF	DK98104200
▲ }		4822 130 32508	DIODE, RL103E/DSF10C	HD20003000	C406		4822 126 11687	CER.CHIP, 0.1µF	DK98104200
▲ D814					C408		9965 000 03906	TANTL.CHIP, 100µF/6.3V	EY10700670
▲ Q701			IC, TDA7056A	HC10157490	C411				
▲ Q703			IC, TDA7056A	HC10157490	}		4822 124 11383	TANTL.CHIP, 10µF/6.3V	EY10600650
▲ Q801		4822 209 61847	IC, NJM78M05FA	HC38505090	C414				
			P701-MISCELLANEOUS		C415		4822 126 11759	CER.CHIP, 100pF ±5% 50V	DD95101300
▲ F001			FUSE, 3.15A 125V	FS10315360	C416		4822 126 11759	CER.CHIP, 100pF ±5% 50V	DD95101300
			UL,CSA,MITI TYPE		C417		4822 126 11687	CER.CHIP, 0.1µF	DK98104200
J704			JACK, HSJ1637-010512	YJ01004520	C418		4822 124 11495	TANTL.CHIP, 47µF/6.3V	EY47600650
▲ S851		4822 276 13242	PUSH SW., SDDL B TV-3 FRAME TYPE C	SP01011830	C419				
			PU01-CD CIRCUIT BOARD		}		4822 124 11383	TANTL.CHIP, 10µF/6.3V	EY10600650
			PU01-CAPACITORS		C422				
C201		4822 126 11682	CER.CHIP, 220pF (GR39)	DK96221300	C423		4822 126 11759	CER.CHIP, 100pF ±5% 50V	DD95101300
C202		4822 126 11682	CER.CHIP, 220pF (GR39)	DK96221300	C424		4822 126 11759	CER.CHIP, 100pF ±5% 50V	DD95101300
C203		4822 126 12495	CER.CHIP, 1500pF (GR39)	DK96152300	C425		4822 126 11687	CER.CHIP, 0.1µF	DK98104200
C204					C426		4822 124 11495	TANTL.CHIP, 47µF/6.3V	EY47600650
}		4822 126 11682	CER.CHIP, 220pF (GR39)	DK96221300	C435		4822 124 11495	TANTL.CHIP, 47µF/6.3V	EY47600650
C206					C436		4822 126 11682	CER.CHIP, 220pF	DK96221300
C207		4822 126 14249	CER.CHIP, W5R 560pF	DK96561300	C451		4822 124 11383	TANTL.CHIP, 10µF/6.3V	EY10600650
C208		4822 126 11682	CER.CHIP, 220pF (GR39)	DK96221300	C452		4822 124 11383	TANTL.CHIP, 10µF/6.3V	EY10600650
C210		4822 126 11687	CER.CHIP, 0.1µF	DK98104200	CU01		4822 126 11704	CER.CHIP, 0.022µF	DK98223300
C211		4822 122 33777	CER.CHIP, 47pF ±5% 50V	DD95470300	CU02		5322 126 11578	CER.CHIP, 1000pF ±10% 50V	DK96102300
C212		4822 126 11567	CER.CHIP, 0.022µF ±10% 16V	DK96223200	CU03		4822 124 21894	ELECT., 10µF/16V	EJ10601610
C215		4822 122 33777	CER.CHIP, 47pF ±5% 50V	DD95470300	CU07		4822 126 13837	CER.CHIP, 0.1µF ±10% 10V	DK96104200
C216		4822 126 11759	CER.CHIP, 100pF ±5% 50V	DD95101300	CU08		4822 124 21901	ELECT., 47µF/6.3V	EJ47600610
C217		4822 126 11687	CER.CHIP, 0.1µF	DK98104200	CU09		4822 126 10935	ELECT., 100µF/6.3V	EJ10700610
					CU10		4822 126 10935	ELECT., 100µF/6.3V	EJ10700610
					CU11		4822 126 11687	CER.CHIP, 0.1µF	DK98104200
			PU01-RESISTORS		R201				
			CHIP RES., 10kΩ ±5% 1/16W	NN05103610	}		4822 051 30103	CHIP RES., 10kΩ ±5% 1/16W	NN05103610
			CHIP RES., 22kΩ ±5% 1/16W	NN05223610	R206				
			CHIP RES., 1MΩ ±5% 1/16W	NN05105610	R208		4822 051 30223	CHIP RES., 22kΩ ±5% 1/16W	NN05223610
					R209		4822 051 30105	CHIP RES., 1MΩ ±5% 1/16W	NN05105610

NOTE : *nsp* PART IS LISTED FOR REFERENCE ONLY, MARANTZ WILL NOT SUPPLY THESE PARTS.

POS. NO	VERS. COLOR	PART NO. (FOR PCS)	DESCRIPTION	PART NO. (MJI)	POS. NO	VERS. COLOR	PART NO. (FOR PCS)	DESCRIPTION	PART NO. (MJI)
R210					R461		4822 051 30222	CHIP RES., 2.2kΩ ±5% 1/16W	NN05222610
}		4822 051 30101	CHIP RES., 100Ω ±5% 1/16W	NN05101610	R462		4822 051 30103	CHIP RES., 10kΩ ±5% 1/16W	NN05103610
R216					R463		4822 051 30103	CHIP RES., 10kΩ ±5% 1/16W	NN05103610
R217		4822 051 30222	CHIP RES., 2.2kΩ ±5% 1/16W	NN05222610	RU01		4822 051 30102	CHIP RES., 1kΩ ±5% 1/16W	NN05102610
R218		4822 051 30101	CHIP RES., 100Ω ±5% 1/16W	NN05101610	RU02		4822 051 30103	CHIP RES., 10kΩ ±5% 1/16W	NN05103610
R219		4822 051 30223	CHIP RES., 22kΩ ±5% 1/16W	NN05223610	RU03		4822 051 30104	CHIP RES., 100kΩ ±5% 1/16W	NN05104610
R220		4822 051 30274	CHIP RES., 270kΩ ±5% 1/16W	NN05274610	RU04		4822 051 30103	CHIP RES., 10kΩ ±5% 1/16W	NN05103610
R221		4822 051 30101	CHIP RES., 100Ω ±5% 1/16W	NN05101610	RU05		4822 051 30101	CHIP RES., 100Ω ±5% 1/16W	NN05101610
R222		4822 117 12968	CHIP RES., 820Ω ±5% 1/16W	NN05821610	RU06		4822 051 30101	CHIP RES., 100Ω ±5% 1/16W	NN05101610
R223		4822 051 30105	CHIP RES., 1MΩ ±5% 1/16W	NN05105610	RU07				
R224		4822 051 30223	CHIP RES., 22kΩ ±5% 1/16W	NN05223610	}		4822 051 30223	CHIP RES., 22kΩ ±5% 1/16W	NN05223610
R225		4822 051 30221	CHIP RES., 220Ω ±5% 1/16W	NN05221610	RU14				
R226		4822 116 83207	CHIP RES., 1.2kΩ ±5% 1/16W	NN05122610	RU20		4822 051 30102	CHIP RES., 1kΩ ±5% 1/16W	NN05102610
R227		4822 051 30222	CHIP RES., 2.2kΩ ±5% 1/16W	NN05222610	RU21		4822 051 30104	CHIP RES., 100kΩ ±5% 1/16W	NN05104610
R228		4822 051 30223	CHIP RES., 22kΩ ±5% 1/16W	NN05223610	RU22		4822 051 30223	CHIP RES., 22kΩ ±5% 1/16W	NN05223610
R251		4822 051 30681	CHIP RES., 68kΩ ±5% 1/16W	NN05681610	RU23		4822 116 82487	CHIP RES., 0Ω ±5% 1/16W	NN05000610
R252		4822 051 30103	CHIP RES., 10kΩ ±5% 1/16W	NN05103610	RU24				
R253		4822 051 30223	CHIP RES., 22kΩ ±5% 1/16W	NN05223610	}		4822 051 30101	CHIP RES., 100Ω ±5% 1/16W	NN05101610
R254		4822 051 30681	CHIP RES., 680Ω ±5% 1/16W	NN05681610	RU42				
R255		4822 051 30103	CHIP RES., 10kΩ ±5% 1/16W	NN05103610	RU43		4822 116 82487	CHIP RES., 0Ω ±5% 1/16W	NN05000610
R256		4822 051 30223	CHIP RES., 22kΩ ±5% 1/16W	NN05223610	RU44		4822 116 82487	CHIP RES., 0Ω ±5% 1/16W	NN05000610
R257		4822 051 30561	CHIP RES., 560Ω ±5% 1/16W	NN05561610					
R258		4822 116 82487	CHIP RES., 0Ω ±5% 1/16W	NN05000610					
R259		4822 051 30153	CHIP RES., 15kΩ ±5% 1/16W	NN05153610	D221		4822 130 83715	CHIP DIODE, 1SS301, DAN202U UMT TYPE	HZ21005000
R260		4822 051 30681	CHIP RES., 680Ω ±5% 1/16W	NN05681610	D401		4822 130 80346	CHIP DIODE, 02CZ8.2-Y	HZ30004050
R261		4822 051 30223	CHIP RES., 22kΩ ±5% 1/16W	NN05223610	DU01		4822 130 80522	CHIP DIODE, 1SS300, DAP202U UMT TYPE	HZ21006000
R262		4822 051 30223	CHIP RES., 22kΩ ±5% 1/16W	NN05223610	DU07		4822 130 80326	L.E.D., LT3D8B RED 30	HI10062320
R263		4822 051 30102	CHIP RES., 1kΩ ±5% 1/16W	NN05102610	Q201		4822 209 91174	IC, SAA7372GP SERVO IC	HC10132490
R264		4822 051 30102	CHIP RES., 1kΩ ±5% 1/16W	NN05102610	Q202		4822 130 61311	CHIP TR.(2SA), 2SA1162 0,Y	HX111622A0
R265		4822 051 30103	CHIP RES., 10kΩ ±5% 1/16W	NN05103610	Q203			DIG.TRS., RN2311,DTA114TU	BA12311000
R266		4822 051 30102	CHIP RES., 1kΩ ±5% 1/16W	NN05102610	Q204			DIG.TRS., RN2311,DTA114TU	BA12311000
R401					Q205			DIG.TRS., DTC114EU	BA20035210
}		4822 051 30103	CHIP RES., 10kΩ ±5% 1/16W	NN05103610	Q206			CHIP TR.(2SB), 2SB789	HX207893B0
R403					Q251		4822 209 16372	IC, TDA7073AT	HC10165490
R404			CHIP RES., 1Ω ±5% 1/16W	NN05010610	Q252		4822 209 16372	SOP DUAL BTL DRIVER	HC10165490
R409					Q401			IC, TDA7073AT	HC10165490
}		4822 051 30104	CHIP RES., 100kΩ ±5% 1/16W	NN05104610	Q402			SOP DUAL BTL DRIVER	HC10020480
R412					Q403			IC, AK4311 1BIT DAC	HC10138490
R413		4822 051 30153	CHIP RES., 15kΩ ±5% 1/16W	NN05153610	Q405			IC, TDA1308 POWER OP AMP	HC10138490
R414		4822 051 30153	CHIP RES., 15kΩ ±5% 1/16W	NN05153610	}		4822 130 63844	DIG.TRS., HN1C03F(B)	BA20016050
R415		4822 051 30101	CHIP RES., 100Ω ±5% 1/16W	NN05101610	Q408				
R416		4822 051 30101	CHIP RES., 100Ω ±5% 1/16W	NN05101610	Q411			CHIP TR.(2SC), 2SC4081 (Q,R)	HX300012A0
R417					QU01			2SC4116 (Y,GR)	HU207NT000
}		4822 051 30102	CHIP RES., 1kΩ ±5% 1/16W	NN05102610	QU02			CPU, TMP87CM21FQFP80	HX300012A0
R420					QU06			CHIP TR.(2SC), 2SC4081 (Q,R)	BA10026210
R421		4822 051 30473	CHIP RES., 47kΩ ±5% 1/16W	NN05473610				DIG.TRS., DTA114EU	
R422		4822 051 30473	CHIP RES., 47kΩ ±5% 1/16W	NN05473610					
R423		4822 051 30101	CHIP RES., 100Ω ±5% 1/16W	NN05101610					
R424		4822 051 30101	CHIP RES., 100Ω ±5% 1/16W	NN05101610					
R425		4822 051 30104	CHIP RES., 100kΩ ±5% 1/16W	NN05104610					
R426		4822 051 30104	CHIP RES., 100kΩ ±5% 1/16W	NN05104610					
R427									
}		4822 051 30101	CHIP RES., 100Ω ±5% 1/16W	NN05101610	FU01				
R430					J201		4822 267 51337	LCD, LM-1606BX	KZ03501860
R431					J202		4822 265 20412	JACK, SLW18R-1C7	YJ06020480
}		4822 051 30102	CHIP RES., 1kΩ ±5% 1/16W	NN05102610	J203			JACK, S2B-PH-K-S	YJ06006420
R434					JU01			JACK, S5B-PH-K-S	YJ06006440
R435		4822 051 30473	CHIP RES., 47kΩ ±5% 1/16W	NN05473610	L241		4822 157 10313	JACK, S9B-PH-K-S	YJ06006490
R436		4822 051 30473	CHIP RES., 47kΩ ±5% 1/16W	NN05473610	L242		4822 157 11808	HF50ACC453215	FN31020010
R438		4822 051 30101	CHIP RES., 100Ω ±5% 1/16W	NN05101610	L251			FERRITE CORE, BLM11B601S CHIPFERRITE	FC90020110
R451		4822 051 30101	CHIP RES., 100Ω ±5% 1/16W	NN05101610				CHOKE COIL,	LC11044600
R453		4822 051 30223	CHIP RES., 22kΩ ±5% 1/16W	NN05223610	L401		4822 157 53872	TSLO709 -101KR66	LU12103010
R454		4822 051 30223	CHIP RES., 22kΩ ±5% 1/16W	NN05223610				CHIP INDUCTANCE, NL322522-100K	LU12103010
R455		4822 116 82487	CHIP RES., 0Ω ±5% 1/16W	NN05000610	L411			CM04RC08T 3LINE FILLTER	FN21000050
R456		4822 116 82487	CHIP RES., 0Ω ±5% 1/16W	NN05000610	LU01		9965 000 04696	CHOKE COIL, 33 UH EL0606	LC13333000
R459		4822 051 30223	CHIP RES., 22kΩ ±5% 1/16W	NN05223610	LU02		4822 157 10313	HF50ACC453215	FN31020010
R460		4822 051 30223	CHIP RES., 22kΩ ±5% 1/16W	NN05223610					

NOTE : "nsp" PART IS LISTED FOR REFERENCE ONLY, MARANTZ WILL NOT SUPPLY THESE PARTS.

POS. NO	VERS. COLOR	PART NO. (FOR PCS)	DESCRIPTION	PART NO. (MJI)
SU01			PUSH SW., TACT SKHLAC	SP01013420
SU02			PUSH SW., TACT SKHLAC	SP01013420
SU03			PUSH SW., TACT SKHLAC	SP01013420
SU04			PUSH SW., TACT SKHLAC	SP01013420
SU05		4822 276 13679	PUSH SW., DETECT SW SPPB51	SP01012350
X221		9965 000 01893	CER.VIB., CSTCC8.46M GOH6TC 8.46MHz ±5%	FQ08464020
XU01		4822 242 80349	CER.VIB., 8.0MHz TYPE(EF0 V) TAPING	FQ08004030
RV01			PV01-VOLUME CIRCUIT BOARD PV01-RESISTORS VAR., 100kΩ	RK01040750

NOTE : "nsp" PART IS LISTED FOR REFERENCE ONLY, MARANTZ WILL NOT SUPPLY THESE PARTS.